



Specification

BRASS SEAT
FLANGED TO EN 1092-2 PN16
FACE-TO-FACE DIMENSION CONFORMS TO DIN3202-F6

Material

Part	Material	BS
Body	Cast Iron	1691 GG25
	Ductile Iron	1693 GGG50
Disc	Ductile Iron	1693 GGG50
Cover	Cast Iron	1691 GG25
	Ductile Iron	1693 GGG50
Seat Ring	Brass	17660 CuZn39Pb3
Disc Ring	Brass	17660 CuZn39Pb3

Pressure / Temperature Ratings

Working Pressure	16 bar
Testing Pressure	Shell: 24 bar Seat: 17.6 bar
Working Temperature	-10°C to 120°C
Suitable Media	Water & Oil

Dimensions

Size mm	L mm	H mm
50	200	127
65	240	151
80	260	165
100	300	178
125	350	205
150	400	221
200	500	249
250	600	306
300	700	330

Structure

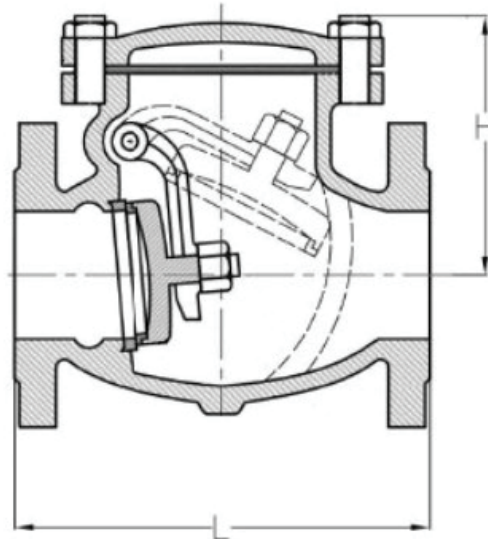

Note:

1. Other flange standards available upon request.
2. Design and specifications are subject to change without prior notice.